

RFQ and Purchase Order Specification Work Sheets

Section: R406.014
Date: 5/28/2020
Supersedes: 11/1/2011
Page 1

TWIP System

TYPICAL ARRANGEMENT

S & W CONN. 1' PIPE PROJECTION

.88 DIA X .38 DEEP RECESS FOR SOCKET WELD 3/8 NPT TAP FOR TEST

COMMON TERMINAL

1/8 DIA HOLE FOR CONDUIT

ELECTRODE NO.

A OVERALL

B STEAM AND WATER CENTERS

TWIP FURNISHED WITH 30-INCH HIGH-TEMPERATURE LEADS CONNECTED TO EACH ELECTRODE FITTING USE 18 A.W.G. TEFLON INSULATED WIRE

ITEM	PART NO.	QTY.	DESCRIPTION	MATERIAL	DWG. NO.
1	EL-1P	1	BODY, SEAMLESS STEEL PIPE	ASTM A106	
2	ELFW-2	1	WP ELECTRODE FITTING HOUSING	SHEET STL.	
3		2	SCREW, R. H. MACH. 10-24 X 3/8	BRASS	
4	X	3	ELECTRODE FITTING ASSEMBLY		
5	X	3	GASKET		
6		1	SCREW, R. H. MACH. 10-24 X 1/2	BRASS	
7		2	NUT, HEX 10-24	BRASS	

A
B

MODEL NO. _____ P. S. I. AT _____

W. S. P. _____ P. S. I. _____

HYDROTEST AT _____ P. S. I. _____

THE CLARK-RELIANCE CORP.
STRONGSVILLE, OHIO U.S.A.

MODEL NO. _____

TWIP COLUMN ASSY.

SCALE: WORK DRAWING: 10-21-971

DRAWN BY: _____

CHECKED BY: _____

NO. TD-3

NOTES:
1) SHUTOFF VALVES SHOULD BE PLACED BETWEEN STEAM DRUM AND TWIP BODY

Please complete all information fields in this worksheet and submit with your RFQ (Request For Quote) or Purchase Order. The use of these worksheets has proven to greatly decrease Engineering time and virtually eliminate specification errors.



16633 Foltz Parkway • Strongsville, OH 44149 USA
Telephone: +1 (440) 572-1500
www.clark-reliance.com • RelianceAppEng@clark-reliance.com

Must accompany P.O with all fields
completed

Customer: _____
Project Name: _____
Project Location: _____
Date: _____

Contact Name: _____
E-mail: _____
Phone Number: _____
RFQ/P.O. Number: _____

TWIP COLUMN REQUIRED INFORMATION

Model No. (See page 3): _____
Design Pressure: _____
Design Temperature: _____

STEAM & WATER CONNS.

(1" MSW Pipe Projection is standard)

Steam & Water Connections (other than standard
– specify size & type Req'd.):

Male Socket Weld
(Pipe Projection): _____
Female Socket Weld: _____
Flange Size: _____
Flange Class: _____
Flange Face: _____
Other (please
specify): _____

DRAIN CONN.

(1/2" FSW is standard with TWIP Column)

Drain Connection (other than standard – specify
size & type Req'd.):

Female Socket Weld: _____
Male Socket Weld
(Pipe Projection): _____
Flange Size: _____
Flange Class: _____
Flange Face: _____
Other (please specify): _____

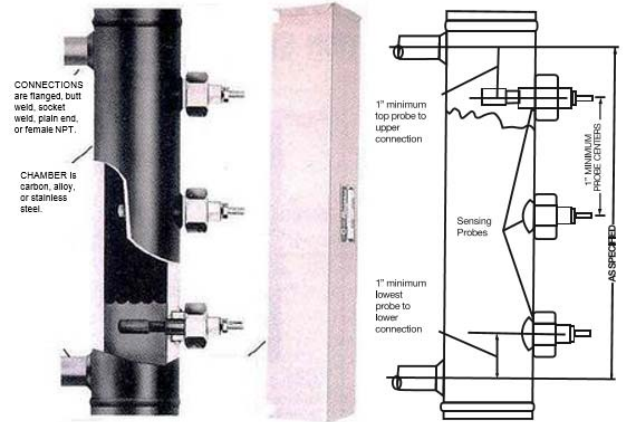

PROBE REQUIREMENTS

Quantity Req'd: _____ Z Brazed Type
"T" Type "FG" Type
"V" Type F Brazed Type
"ZG" Type FSB Compression

MATERIAL REQUIREMENTS

Carbon Steel:
P22 Chrome-Moly
P91 Chrome-Moly
Type 316 Stainless Steel

OPTIONS REQUIRED

Integral junction box: NEMA 4 NEMA 4X
Additional probe wire
(specify length required): _____
FlexPak Insulation Jacket:

TWIP® Model Numbering Code

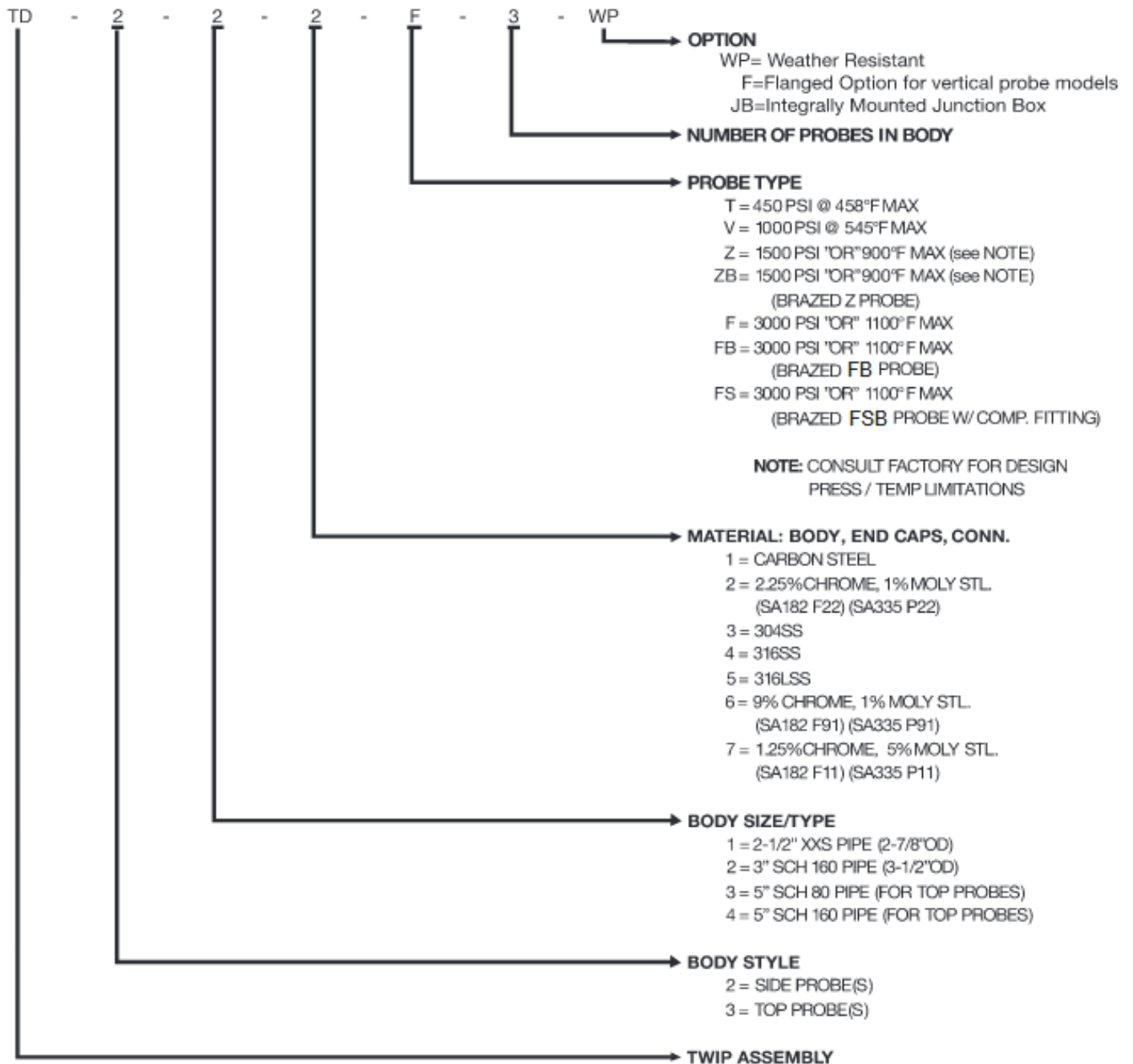

Consult factory for NDE requirements on applications over 750°F (400°C).

REQUIRED DIMENSIONAL INFORMATION

Section: R406.014
Date: 5/28/2020
Supersedes: 11/1/2011
Page 4

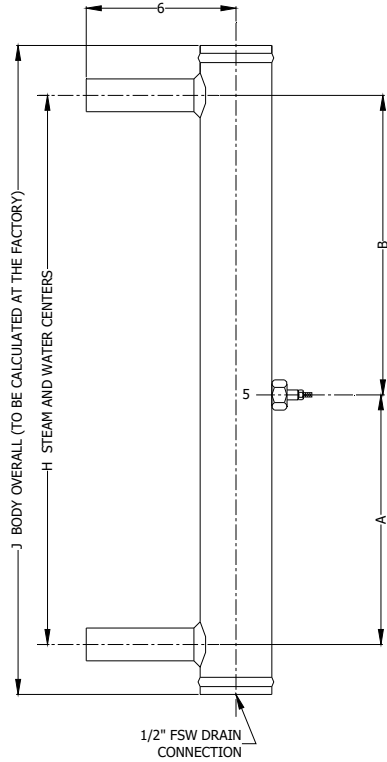

A	
B	
H	
J	-----

1 PROBE TWIP COLUMN

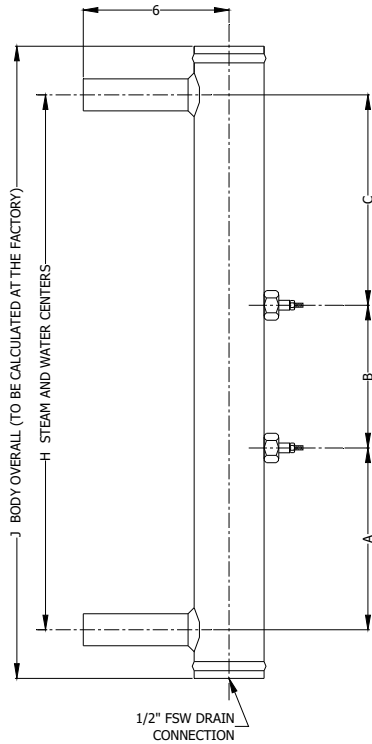

A	
B	
C	
H	
J	-----

2 PROBE TWIP COLUMN

DIMENSIONAL NOTES:

- 1) MINIMUM DISTANCE BETWEEN PROBES IS 1"
- 2) MINIMUM "A" DIMENSION IS 1"
- 3) MINIMUM DISTANCE BETWEEN TOP PROBE AND STEAM CONNECTION (UPPER CONNECTION) IS 1"

Additional notes:

REQUIRED DIMENSIONAL INFORMATION

Section: R406.014
Date: 5/28/2020
Supersedes: 11/1/2011
Page 5

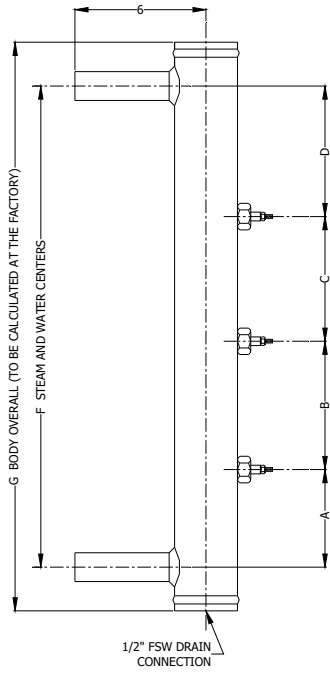

A	
B	
C	
D	
H	
J	-----

3 PROBE TWIP COLUMN

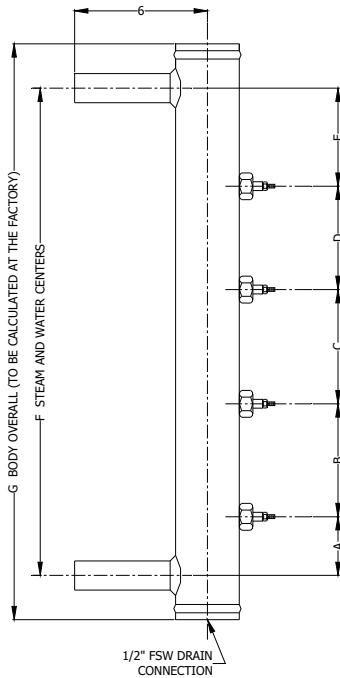

A	
B	
C	
D	
E	
H	
J	-----

4 PROBE TWIP COLUMN

DIMENSIONAL NOTES:

- 1) MINIMUM DISTANCE BETWEEN PROBES IS 1"
- 2) MINIMUM "A" DIMENSION IS 1"
- 3) MINIMUM DISTANCE BETWEEN TOP PROBE AND STEAM CONNECTION (UPPER CONNECTION) IS 1"

Additional notes:

REQUIRED DIMENSIONAL INFORMATION

Section: R406.014
Date: 5/28/2020
Supersedes: 11/1/2011
Page 6

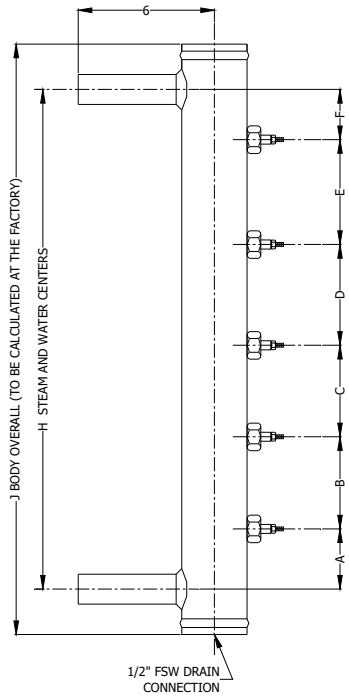

A	
B	
C	
D	
E	
F	
H	
J	-----

5 PROBE TWIP COLUMN

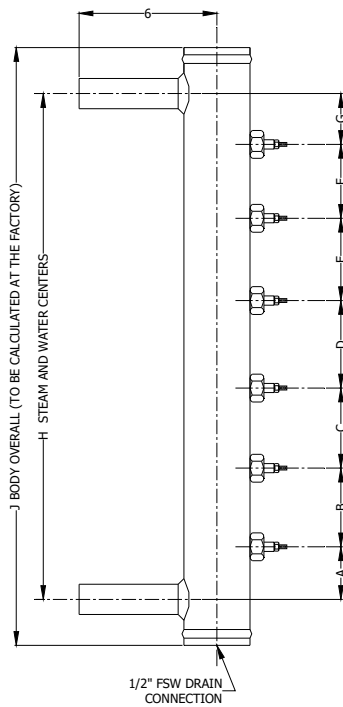

A	
B	
C	
D	
E	
F	
G	
H	
J	-----

6 PROBE TWIP COLUMN

DIMENSIONAL NOTES:

- 1) MINIMUM DISTANCE BETWEEN PROBES IS 1"
- 2) MINIMUM "A" DIMENSION IS 1"
- 3) MINIMUM DISTANCE BETWEEN TOP PROBE AND STEAM CONNECTION (UPPER CONNECTION) IS 1"

Additional notes:

CONTROL UNIT REQUIRED INFORMATION

Base Model Number:

No Indicator R#00L

With Indicator ECIL-#R

= Number of relays required (One relay for each probe)

Power Requirements:

120 VAC

240 VAC

Enclosure Required

NEMA 1 (Std.)

NEMA 4 (W'proof)

NEMA 4X (W'proof

Stn. Stl.)

NEMA 7 (Ex'proof)

No Enclosure Req'd.

Conduit hubs

Quantity _____ Size _____

Environment:

Indoor

Outdoor

Hazardous Area

Options Required:

- Slave Relays for additional Aux. contacts
- Voting Logic Package
- Dead Band Relays
- ECID-66 Intrinsically Safe Barrier for probe circuit
- ECID-67 Intrinsically Safe Barrier for indicator circuit

Relay Requirements:

Direct Mode (Std.)

Inverse Mode (Specify Probe Location) _____

Water Conductivity (Normal is 10 – 50 mho) _____

Time Delay (Specify Probe Location) _____

Other Requirements: _____

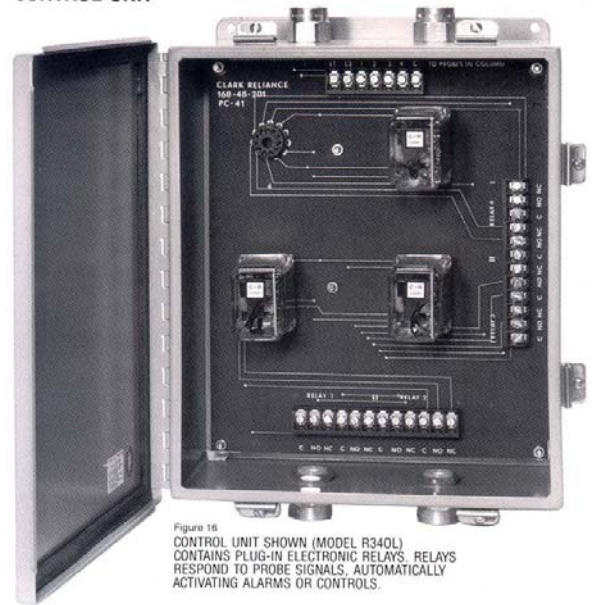

Figure 16
 CONTROL UNIT SHOWN (MODEL R340L)
 CONTAINS PLUG-IN ELECTRONIC RELAYS. RELAYS
 RESPOND TO PROBE SIGNALS, AUTOMATICALLY
 ACTIVATING ALARMS OR CONTROLS.

INDICATOR REQUIRED INFORMATION

Type of Indicator Required

- MTI Miniature LED Indicator (Red Lights only)
- MTI Miniature LED Bi-color Indicator (Red/Green Lights)
- SMI Sub-miniature LED Bi-color Indicator (Panel Mount)
- SMI Sub-miniature LED Bi-color Indicator (Encl. Door Mount)

Environment

- Indoor
- Outdoor
- Hazardous Area

Indicator Options

- Wall Mounting Bracket
- Weatherproof Enclosure
- Weatherproof Enclosure – NEMA 4X Stainless Steel
- Conduit hubs
Quantity _____ Size _____
- NEMA 7/4 Enclosure for SMI Indicators only



OPTIONAL MINIATURE INDICATORS CAN ALERT PERSONNEL TO PRESENCE OF UNWANTED WATER OR ACTUATION OF RELAYS

CABLE REQUIREMENTS

Amount Required (only available in lengths of 100, 500, or 1000 feet)

- _____ X174882 18 AWG Cable 15 Conductor
- _____ X174883 18 AWG Cable 25 Conductor
- _____ X174808 18 AWG Shielded Cable 4 Conductor
- _____ X174886 16 AWG Cable 19 Conductor (High Temp.)
- _____ X174887 16 AWG Cable 4 Conductor (High Temp.)
- _____ X174895 16 AWG Cable 9 Conductor (High Temp.)